

THIS MANUAL CONTAINS HELPFUL HINTS
ON:

Installation of DynaFlight-SeisBagII™

DynaFlight-SeisBagII™ Airborne Seismic Bag
Guidance and Management system

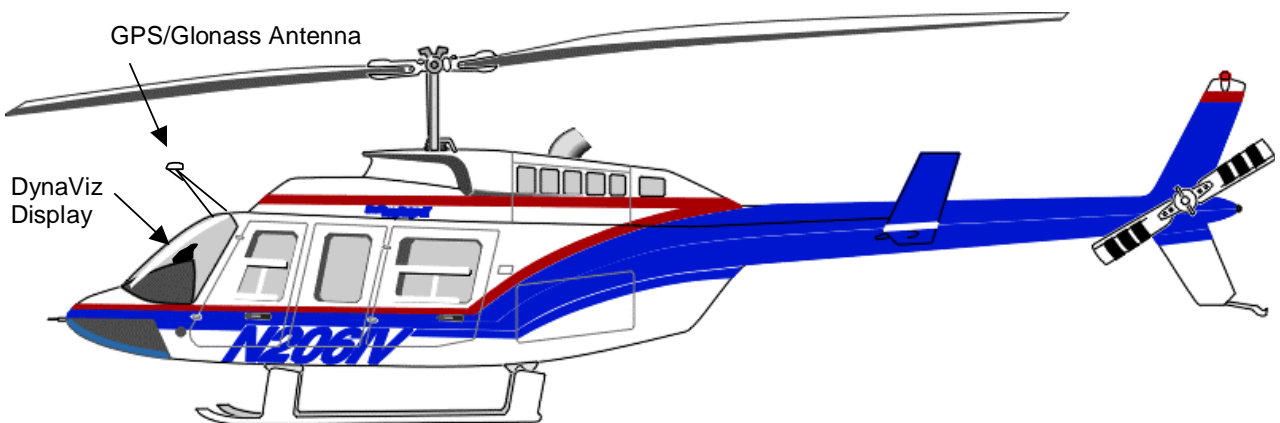

INDEX

Table of Contents

Overview of System	3
Mounting.....	3
GPS/G LONASS Antenna	3
Overview.....	3
Placement	3
Telemetry and/or Differential Antenna.....	3
Overview.....	3
Placement	3
Processor box.....	4
Overview.....	4
Placement	4
Pilot Display.....	4
Overview.....	4
Placement	4
Product features.....	4
Control Grip or Switches	5
Overview.....	5
Placement	5
Product features.....	5
DB I/O Control Box	5
Overview.....	5
Placement	5
Wiring Harness Diagrams.....	5
Overview.....	5
Supplied Parts List	6
Basic DynaFlight-SeisBag™ airborne system contains:	6
Optional Telemetry-Air Module Contains:	6
Optional Telemetry-Ground Module for SeisBag Ground™ contains:.....	6
Appendix	7
Wiring Diagrams	7
DynaViz Display Wiring Harness.....	7
Control Cable and Switch Interconnect Wiring	8
Dimensional Drawings and Renderings.....	9
DynaViz Display Diagram	9
DynaByte Processor Box Back View Diagram	9
DynaByte Bottom Mounting Plate Diagram	10

DynaNav Installation Manual

Overview of System

The DynaFlight-SeisBag™ system is an electronic guidance and data management system specifically designed as a tool for the pilot to fly direct to and locate seismic bag deploy points and to return back to the that exact point to retrieve the bag. The system also automatically senses deploying and retrieving for recording and displaying the status of these deploy/retrieve events and displays this to the pilot as well as the ground bag management personnel when the data is transferred. The system can be temporarily or permanently installed and approved,

Mounting

GPS/G LONASS Antenna

Overview

As the GPS/GLONASS antenna has two functions, one, to view the full constellation of orbiting satellites and two, to view the geo-stationary satellite positioned over the equator, the antenna should have as much visibility of the full sky as possible.

Placement

The GPS/GLONASS antenna should be mounted on top of the helicopter and should take into consideration the following, see figures 1, 2 and 3 (note on a Bell 206 figures 1 and 3 are preferred.):

- Mount the antenna as far forward on the top as possible while keeping the antenna as flat to the horizon as possible. This is to keep it away from the rotor mast as much as possible as well as lead the pilot to the spot.
- Should be mounted on a metal surface where possible or provide a minimum 6" square ground plain.
- The antenna should be mounted high enough to see as much of the sky above and around so as the fuselage does not block the signal.
- Mounting on the tail would be a last resort and for maximum accuracy should only be done if Laser Gyro option is installed in the DynaFlight.
- Keep as far away from transmitting antennas as possible (at least 12 inches) If this is not possible, please contact DynaNav for recommendations.

Telemetry and/or Differential Antenna

Overview

As the Telemetry/Differential antenna has to view the ground based broadcast antenna, the antenna should be outside the aircraft and have visibility of this base antenna.

Placement

The ideal location for this antenna is on the bottom of the helicopter and as vertical as possible with the following considerations:

- Keep away from other communications antennas as far as possible.
- Do not mount immediately next to gear struts of hook assembly
- The shorter the coax the better the range.

Processor box

Overview

The DynaByte processor box contains all the electronics of the system. It also contains a magnetic compass for establishing the orientation of the helicopter in hover. As the DynaFlight calibrates the compass to the direction of the helicopter on first flight after turn on, the specific direction around the vertical axis is not critical. The SeisBagII Processor box has a Mounting Plate that has 4 side tabs with 8 mounting holes. This plate can be modified by removing either set of mounting tabs to best fit installation.

Placement

The DynaByte processor box should be mounted either horizontal or vertical depending on the direction that the internal compass has been mounted. The internal compass can be changed to either horizontal or vertical orientation in the field to suit the best mounting configuration for the helicopter.

Pilot Display IFGI (Integrated Flight Guidance Instrument)

Overview

The IFGI pilot display is intended to be a “heads-up” type of display to be placed in the field of view of the normal operation of the helicopter pilot. As such this *DynaViz™* display has multiple functions including the following:

- Guidance display to guide pilot directly to the bag (or other asset) location to be deployed or retrieved.
- Pilot display for selecting specific target area and location.
- A moving map display to show Bag location pattern and statuses.

Placement

The display should be mounted to best suit the requirements of both the pilot and the specific helicopter. This should take into consideration the following:

- It should be somewhere in the scan area of the pilot, that is, somewhere between the down view of the long line and the forward view.
- The sun shroud (used on the EL type display) should be positioned for full screen visibility for the pilot while occluding direct sunlight on the screen. As the bottom mount can be tilted from 0 to 45 degrees to adjust for individual pilot needs, be sure the bottom plate is mounted to allow for individual pilot needs (tall or short).
- The front of the screen should be oriented to front of helicopter to give guidance information that relates to helicopter flight direction.

Product features

- The connector plug for the DynaViz™ display can be switched from side to side to meet installation requirements whether harness enters from either left or right side.
- As the display represents the ground view, the display should be mounted as horizontal as possible so as the pilot can see the complete screen. The EL display can be viewed at quite extreme angles and can use either the tunnel sun shroud or the angled sun shroud. The LCD display is limited to the angle off the center view.
- The connector plug is a LEMO connector that is simply pushed on (align red dots first) and pulled off.
-

Control Grip or Switches

Overview

The control grip contains three primary switches that control the entire system. On our supplied grip assembly, two of these switches are contained in the single 5 way Top Hat switch. It is the intention of the system for the pilot to have access to these switches either on his cyclic or his collective or a combination of both. Other than these switches, the DynaFlight system is wire to sense other actions such as deploying or retrieving.

Placement

If the cyclic or collective has a spare Top Hat switch, it can be wired directly to the connector on the Dual Relay box, along with two other push buttons for the “accept” and the “window “ operation. This Dual Relay box should always be used as it contains the transient spike protection circuitry. If the ErgoGrip™-Collective switch box is used, it should be attached to the collective such that it does not interfere with the normal operation and so the top hat can be operated with the thumb.

Product features

With the grip or collective switch box in the pilots hands, the pilot will be able to change job functions while observing the display to keep his field of view outside the helicopter, not inside the cockpit.

DB I/O Control Box

Overview

The DB I/O Control box has multiple functions to interface the aircraft and the pilot to the DynaNav system. These functions are as follows: NOTE: THIS BOX MUST BE INSTALLED IN ALL IN INSTALLATIONS TO PROTECT THE COMPUTER.

- To interface to and sense both of the deploy and the retrieve relays of the Seismic Bag carousel operation.
- To protect the DynaNav from the electrical spikes generated by the relay action
- To protect the DynaNav system from static discharge on the control switches
- To interface multiple style of control switch assemblies.

Placement

The Control box is connected directly to the DynaFlight interface harness which is usually within 2 feet of the back of the DynaFlight processor box. From the relay box two harnesses are connected, the deploy/retrieve sense lines and the control switch module.

Wiring Harness Diagrams

Overview

The diagrams attached to appendix are for the interconnect wiring of the DynaNav system. All wires on the harnesses supplied (except the control grip/box)

Supplied Parts List

Basic DynaFlight-SeisBag™ airborne system contains:

- DynaByte-SeisBagII™- Processor Box
- DynaViz™ Electro-luminescent display unit
- DynaViz-Cable 10 foot Display interconnect cable
- GPS/GLONASS Antenna Kit GPS/GLONASS Antenna kit with 15 foot coax cable
- DB-Cable3 Control Cable from DynaByte to ErgoGrip 6"
- ErgoGrip™-Collective 5 way Top Hat control switch as well as Enter switch with 8foot cable assembly.
- DB-I/O Control Dual relay box for dual sensing of deploy and retrieve
- DB2-24cable9 Deploy/Retrieve 9 ft. wire and plug
- DB-PowerCable Power Plug/Cable 18" with DB-8' wired cable
- DynaFlight-SeisBagII™ Airborne Software Module Software Version 3.0
- Pelican Shipping Carrying Case
- SeisBag- Ground™ Software Version 4.5 module

Optional Telemetry-Air Module Contains:

- SS-Telemetry-Remote-Air Aircraft to ground 900 Mhz spread spectrum bi-directional RF telemetry module. Includes airborne vertical spike antenna and coax cable.

Optional Telemetry-Ground Module for SeisBag Ground™ contains:

- SS-Telemetry-Remote-Base An Ground to Aircraft 900 mhz spread spectrum bi-directional telemetry modules for base computer. One module required for each base or remote.
- SS900 Base Antenna Telemetry Base Antenna 6db gain

Specifications:

- Includes WAAS,
- DynaViz™ Display Unit – EL flat panel display showing position, moving-map, guidance and operating buttons, for a safe operation.
- **DynaByte™ – rugged environmentally resistant enclosure with military spec. connectors.**
- Tophat and MS switch for integration into collective or cyclic.
- Windows based software with Installation manual and quick reference user guide.
- GPS/GLONASS Engine is sub-meter and presented at ten position solutions per second or better.
- Optional Telemetry-Remote for live tracking as well as DynaMap™ for creating background maps for ground and Air.

Environmental:

Display Unit

Operating Temp: -30 to +50 degrees C.

Storage Temp: -40 to +70 degrees C.

Humidity: 5 to 95%, non-condensing

EMI/RFI: DOC, FCC

Physical: DynaByte™ Processor DynaViz™

Width: 7.25 ins (18.5cm)

Height: 6.5 ins (16.5cm)

Depth: 5 ins (13cm)

Weight: 4.4lbs (1.7kg)

6.25 ins (16cm)

5.25 ins (13cm)

6.5 ins (16cm)

1.6 lbs (.6kg)

Installation kit including antenna and Tophat - 5 lbs. (1.9kg) Please note: Specifications subject to change without notice.

8-40 VDC, negative ground (system requires less than 14 watts)

Appendix

Wiring Diagrams

DynaViz Display Wiring Harness

DynaViz (IFGI) Display Harness

Rev A - 13Apr2011

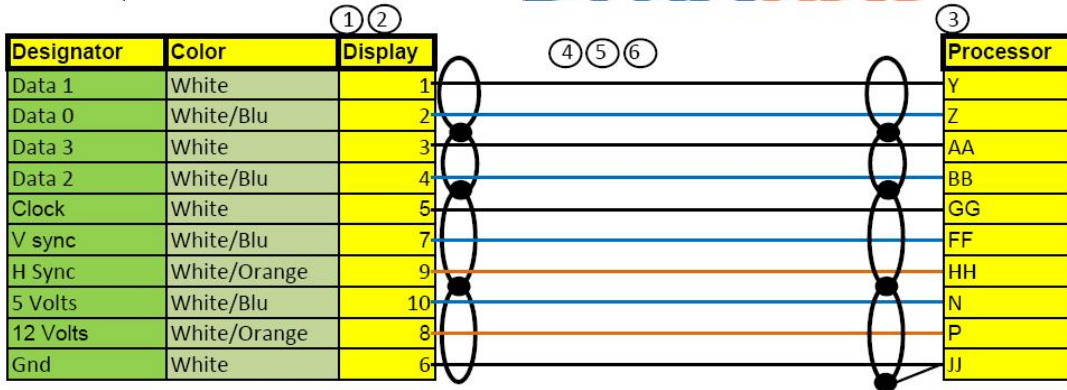

Item	Part Number	Description	Qty
1	FGG2B310CLAD72Z	Lemo 10 Pin Plug	1
2	GMA2B-070-Blk	Lemo Strain Relief	1
3	PW06F18-32P	32 Pin Plug	1
4	M27500-24TG2T14	2 wire Shielded #24 wire	10 Feet x 2
5	M27500-24TG3T14	3 wire Shielded #24 wire	10 Feet x 2
6	XS100-1/4"	Expando	10 Feet

Lemo Connector viewed from the Solder side (inside)

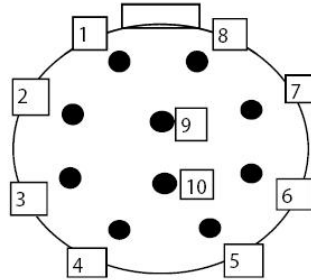

Control Cable and Switch Interconnect Wiring

SeisBagII DB Control Cable

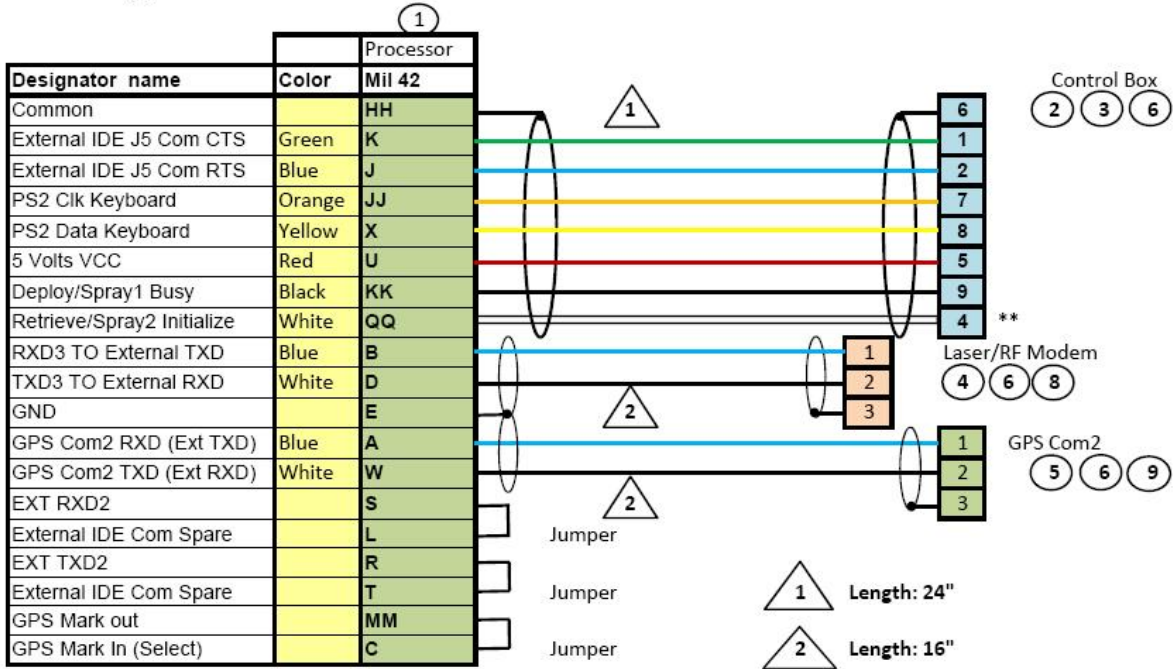

Item	Part Number	Description	Qty
1	PW06F20-41P	Mil 41 Pin Male Plug	1
2	206485-1	9 Pin Female Plug	1
3	206062-3	Cable Clamp	1
4	1445510-3	3 Pin Male Plug	1
5	1445534-3	3 Pin Female Plug	1
6	1445730-1	Cable Clamp	2
7	205090-1	AMP Socket	8
8	770985-1	AMP Pin	3
9	770986-1	AMP Socket	3
10	M27500-22TG7T14	7 Wire Shielded	2
11	M27500-24TG2T14	2 Wire Shielded	2.5

VCC 5 Vdc		5	**Jump Pin 6 of ribbon Cable to Pin 4 of 9 Pin plug (Inside Box)
GND/ Shield		6	
External IDE J5 Com RTS		2	
External IDE J5 Com CTS		1	
KEYCLOCK		7	
KEYDATA		8	

Dimensional Drawings and Renderings

DynaViz Display Diagram

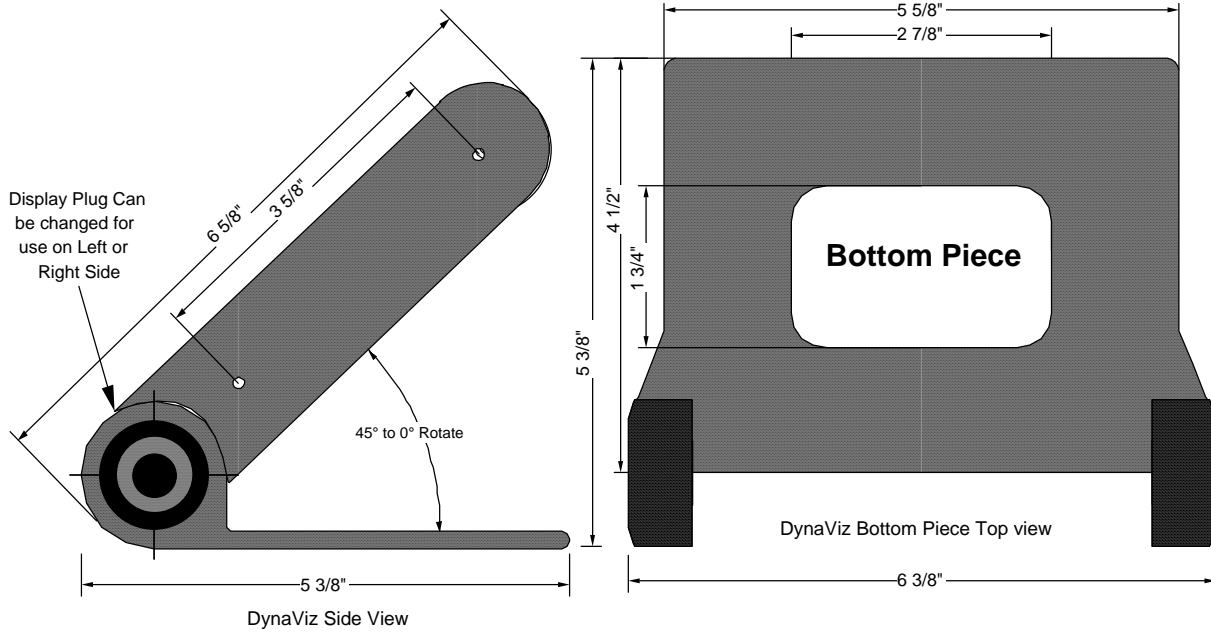

DynaByte Processor Box Back View Diagram

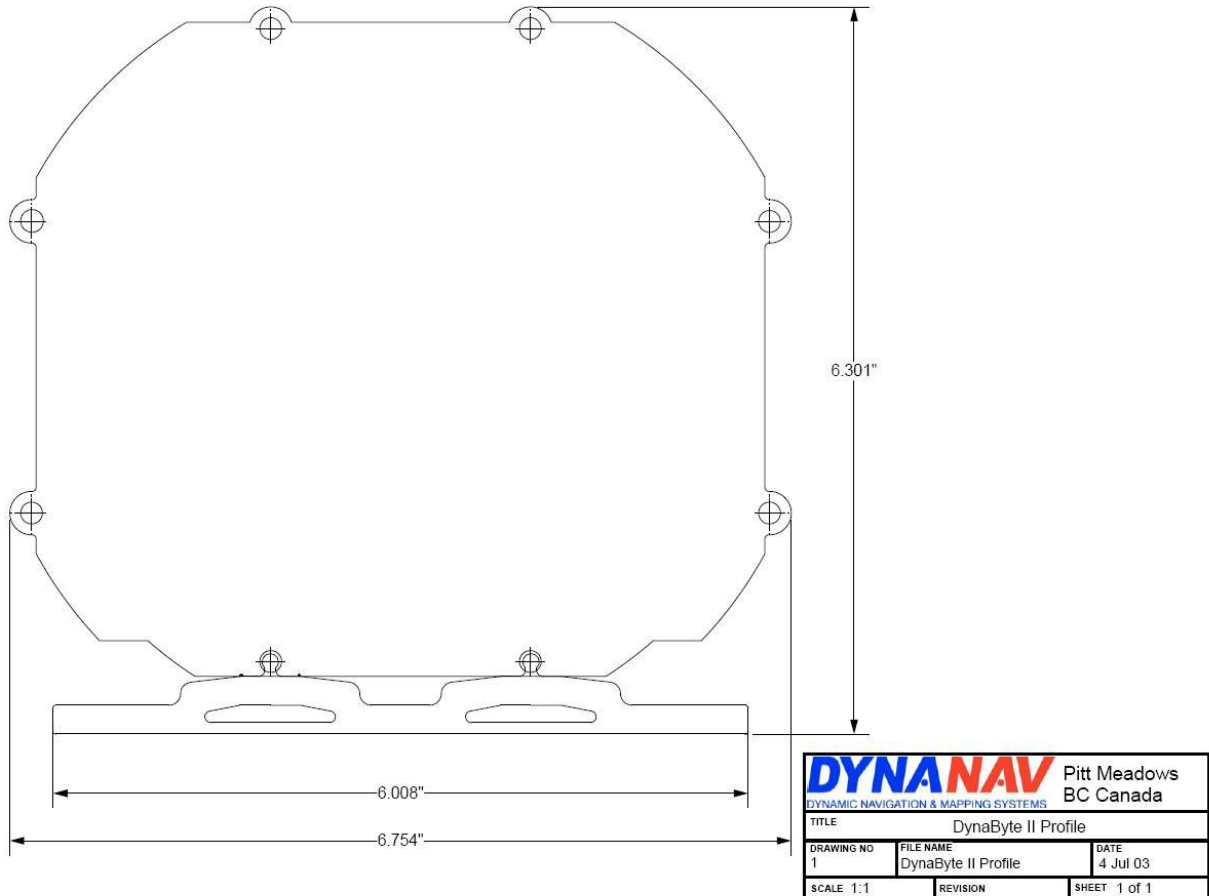

DynaByte Bottom Mounting Plate Diagram

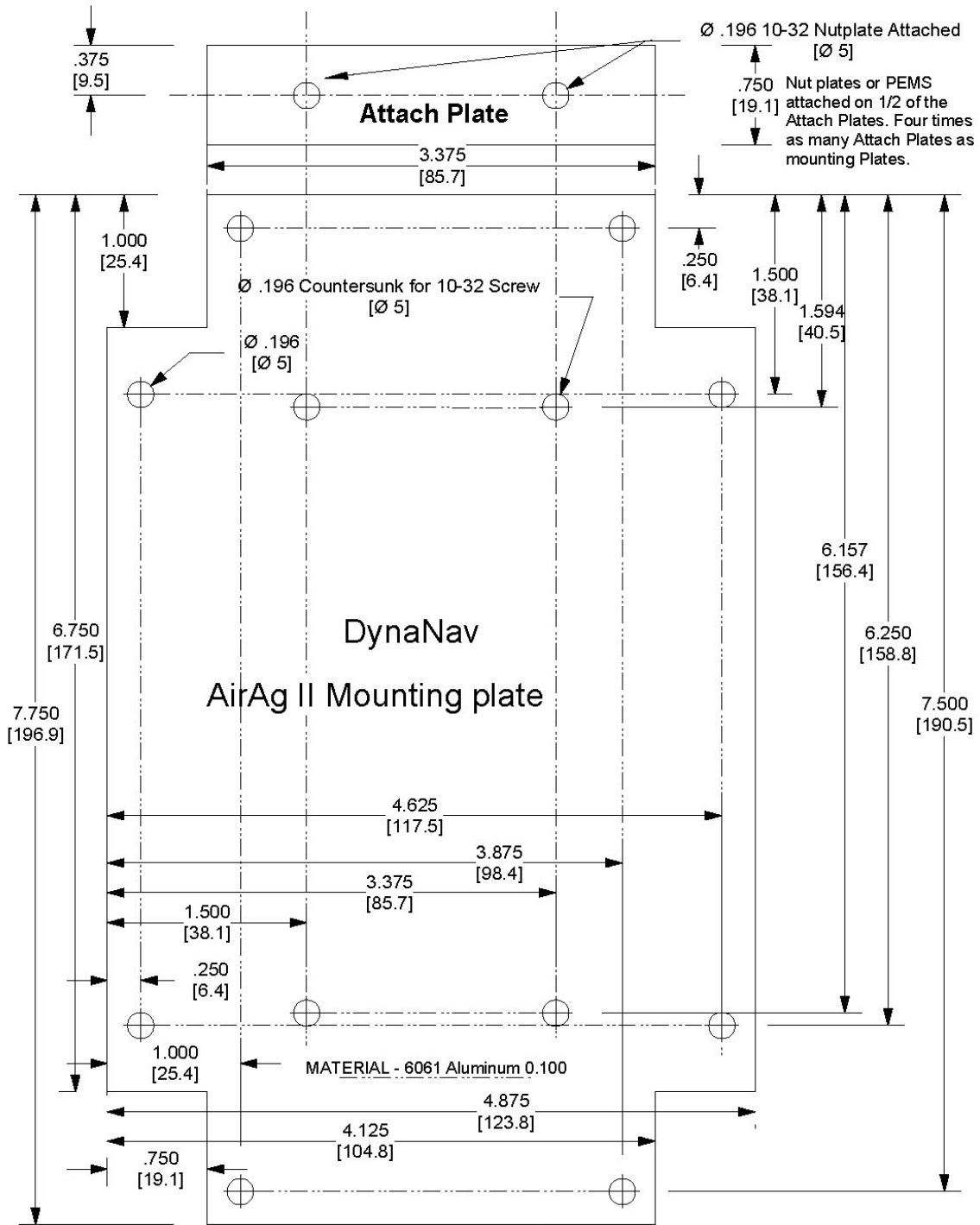

DYNANAV Pitt Meadows DYNAMIC NAVIGATION & MAPPING SYSTEMS BC Canada	
TITLE AirAg II Mounting plate	
DRAWING NO 1	FILE NAME Mounting Plate AirAgII
DATE 1 Nov 02	
SCALE 1:1	REVISION
SHEET 1 of 1	

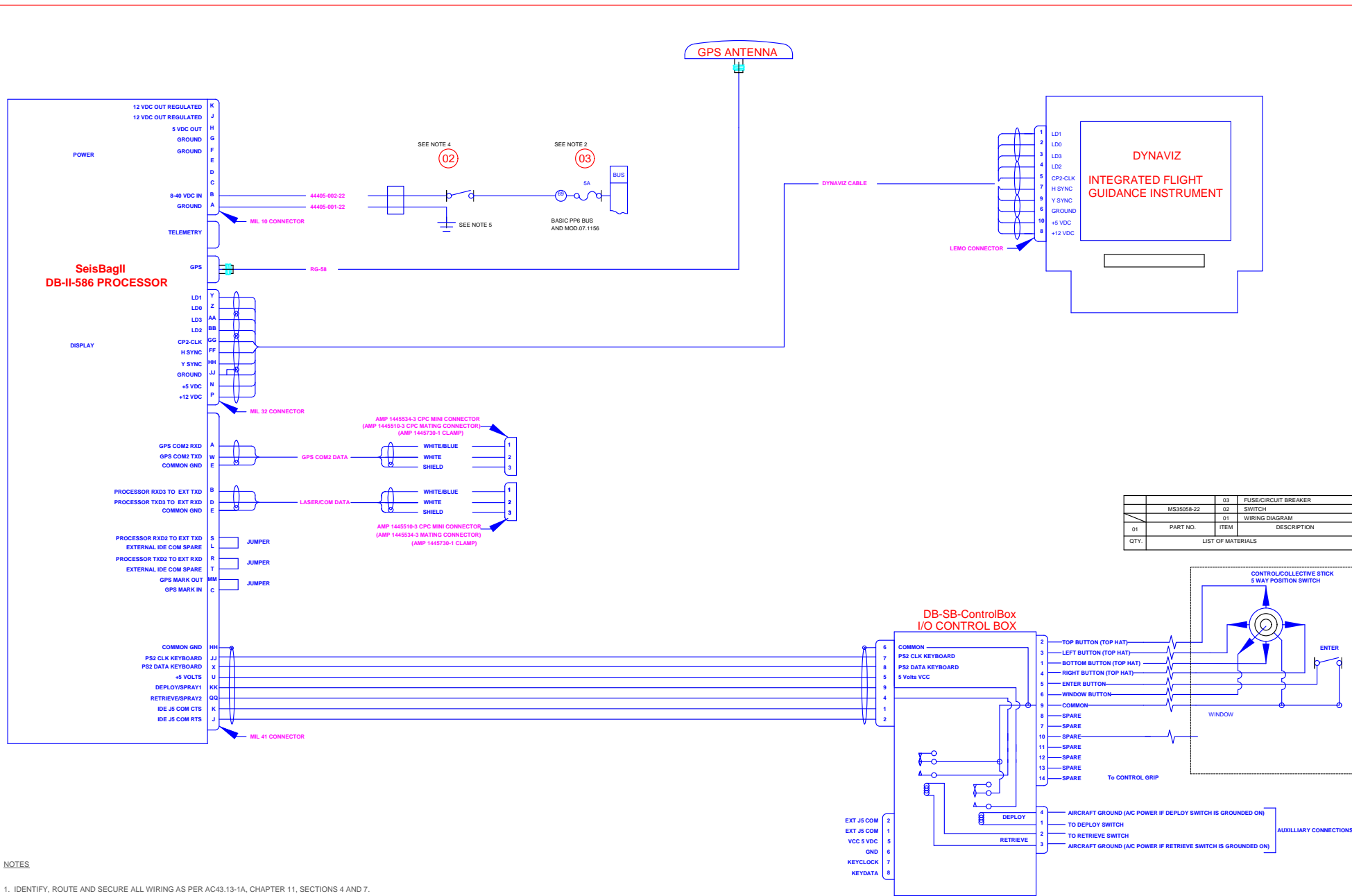

NOTES

- IDENTIFY, ROUTE AND SECURE ALL WIRING AS PER AC43.13-1A, CHAPTER 11, SECTIONS 4 AND 7.
- IF DESIGNATED FUSE/CIRCUIT BREAKER LOCATION IS USED BY OTHER INSTALLATION, LOCATE 5 AMP FUSE/CIRCUIT BREAKER IN CONVENIENT UNUSED LOCATION IN FUSE PANEL. LABEL FUSE "DYNANAV".
- ALL WIRING UNLESS OTHERWISE MARKED IS MIL-W-22759/16. THE LAST DASH NUMBER INDICATES WIRE GAUGE.
- LOCATE SWITCH ON PANEL CONVENIENT FOR PILOT AND LABEL "DYNANAV".
- ATTACH GROUND TO EXISTING GROUND SCREW.